

12
VOLT

GATE OPERATOR ARM 2000ENC

For gate leaves up to 3 m

EN
12445
12453
COMPLIANT



650ARM2000ENC

12 V electromechanical covered screw gate operator with encoder. Maximum gate leaf 3 m

Features:

- residential use
- for gates leaves up to 3 m
- low voltage DC gate operator
- optical encoder technology
- covered screw gate operator
- adjustable mounting brackets

Pros:

- obstacle detection and crush prevention
- in accordance with EN 12445-12453 standards
- works even during power outage thanks to the optional backup battery
- fast operating speed
- soft start and soft stop
- intensive use, ideal for use on apartment buildings and public entrances
- bronze lead nut for strength and silent operation
- electrical connections are easier thanks to the larger upper space
- quick and easy installation

Technical features	ARM2000ENC
Power supply	230 V AC (50 - 60 Hz)
Motor power supply	18 V DC
Absorption	1,3 A
Absorbed power	24 W
Opening time 90°	12 sec.
Duty cycle	100 %
Max. thrust	2600 N
Operating temperature	-20° C ÷ +55° C
Motor thermal protection	-
Degree of protection	IP 44



Easy mounting

Multi-position adjustable brackets allow greater flexibility during assembly even on non standard sized posts



Manual release with personal key

Easy-to-operate manual release with key lock for the less skilled users

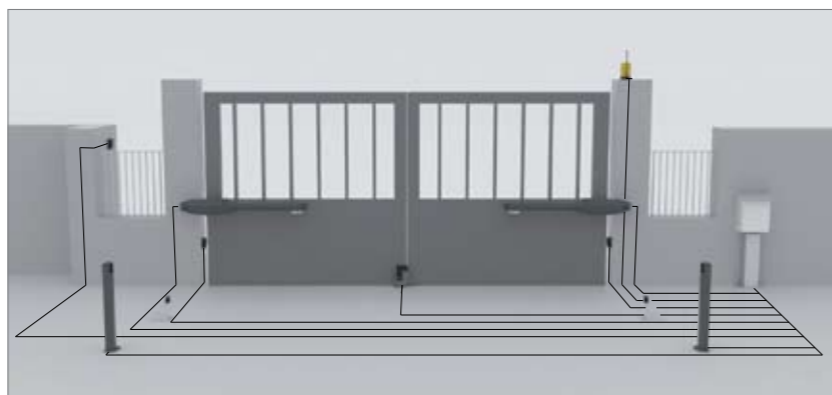

The above represented installation does not include safety devices such as safety edges. Their addition depends upon the risk assessment made on any installation in accordance with EN 12445-12453 standards.



KARM2000BT

Complete double arm automation kit for gates up to 3 + 3 m, with two 650ARM2000ENC gate operators

Accessories included in the kit:



900OPTIC



750D747M



250RXDC1



300T-KEY
aluminium
+ LED TSL



250ANTD



900LAMP4



250K-SLIMRP



BRACKETS



C-CRT

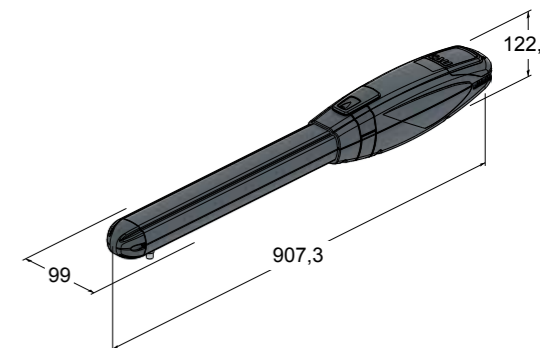

Accessories



200BATT
12 Volt Battery, 7,2 Ah



650ESV1-2
Electric lock (1 = left hand
opening - 2 = right hand
opening)



750D747M
Electronic control unit
for one or two 12 V gate
operators with encoder,
complete with transformer
and enclosure



700BAP
Gate stopper for heavy
leaves



750SCB12
Battery charger (optional)



700BAP1
Gate stopper for light leaves



M-030000CC50
Multicore cable (2 x 2,5
sq.mm + 3 x 0,5 sq.mm)



700BAP2
Gate stopper wall/floor
mount



700GS5
Weatherproof cable
connector for 5-core 12 V
cable



C-TARG
Aluminium CE Mark Label,
self adhesive

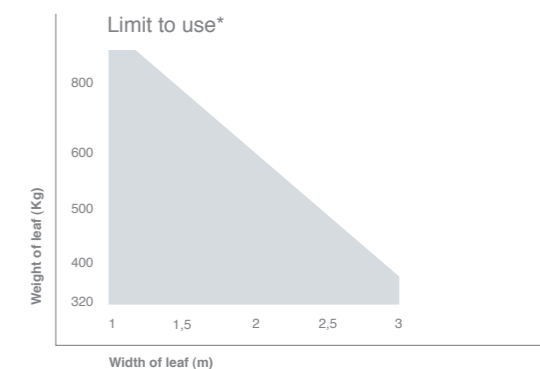

*They refer to leaves with openings and not totally closed panels.

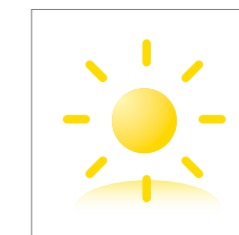

Solar power
Thanks to the Photovoltaic (PV) Technology, every low voltage DC gate operator can be solar powered. Discover the advantages of the solar energy at page 124



Further accessories:
Transmitters page 104
Photocells page 110
Flashing lights page 113

⚠ Use only M-030000CC50 cable or equivalent

📄 See page 128 for assembly measurements and opening angle

ARM 2000/F/FC

For gate leaves up to 3 m



650ARM2000

230 V electromechanical covered screw gate operator. Maximum gate leaf 3 m

650ARM2000F

230 V electromechanical covered screw gate operator with opening limit switch. Maximum gate leaf 3 m

650ARM2000FC

230 V electromechanical covered screw gate operator with opening and closing limit switches. Maximum gate leaf 3 m

Features:

- residential use
- for gates leaves up to 3 m
- 230 V gate operator
- built-in capacitor
- available with or without electro-mechanical limit switches
- covered screw gate operator
- adjustable mounting brackets

Pros:

- bronze lead nut for strength and silent operation
- electrical connections are easier thanks to the larger upper space
- quick and easy installation
- manual release with key lock
- high torque and power



Easy mounting

Quick and easy installation thanks to the multi-position adjustable mounting brackets supplied with each gate operator.



Adjustable limit switches

Electro-mechanical limit switches allow gate position adjustment even when gate stoppers are not used

Technical features	ARM2000/F/FC
Power supply	230 V AC (50 - 60 Hz)
Motor power supply	230 V AC
Absorption	1,5 A
Absorbed power	280 W
Opening time 90°	20 sec.
Duty cycle	36 %
Max. thrust	2300 N
Operating temperature	-20° C ÷ +55° C
Motor thermal protection	160° C
Degree of protection	IP 44

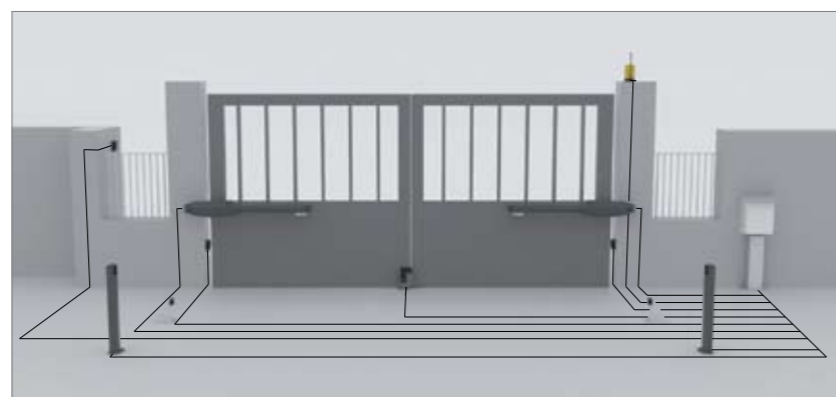

The above represented installation does not include safety devices such as safety edges. Their addition depends upon the risk assessment made on any installation in accordance with EN 12445-12453 standards.



KARM2000T

Complete double arm automation kit for gates up to 3 + 3 m, with two 650ARM2000 gate operators

Accessories included in the kit:



900OPTIC



750D750M



300T-KEY
aluminium +
LED TSL



250ANTD



900LAMP3



250K-SLIMRP



BRACKETS



C-CRT

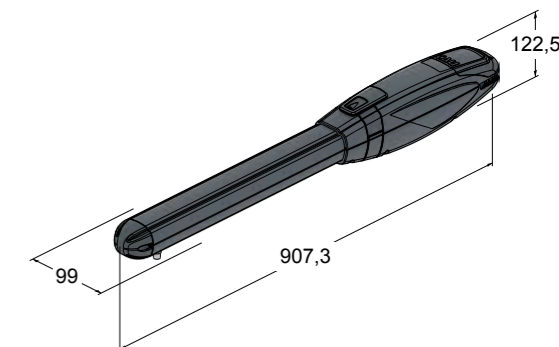

Accessories



750D750M
Electronic control unit for one or two 230 V gate operators with soft-stop and built-in 433,92 MHz radio receiver, complete with enclosure



700BAP
Gate stopper for heavy leaves



S-750D752M10
Control unit enclosure protective lid



700BAP1
Gate stopper for light leaves



700GS3
Weatherproof cable connector for 3-core 230 V cable



700BAP2
Gate stopper wall/floor mount



650ESV1-2
Electric lock (1 = left hand opening - 2 = right hand opening)



C-TARG
Aluminium CE Mark Label, self adhesive

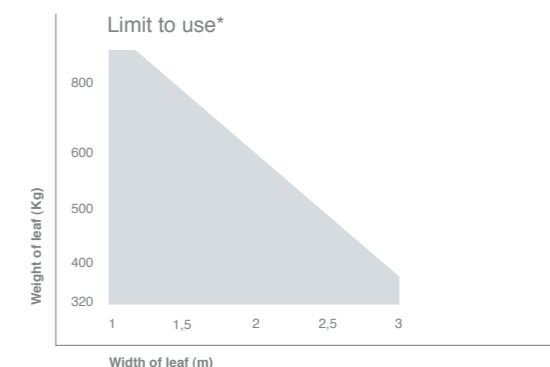

*They refer to leaves with openings and not totally closed panels.



Further accessories:
Transmitters page 104
Photocells page 110
Flashing lights page 113

See page 128 for assembly measurements and opening angle